



Avionics Domain KARYON Project Results

11/10/2014



AGENDA

- Scenario Description
- Safety Kernel Components Architecture
- Test Environment
- Demonstrations

SCENARIO DESCRIPTION

- Demonstrate KARYON functionalities in an aeronautical application and how it may improve the usage of local airspace without compromising flight safety.

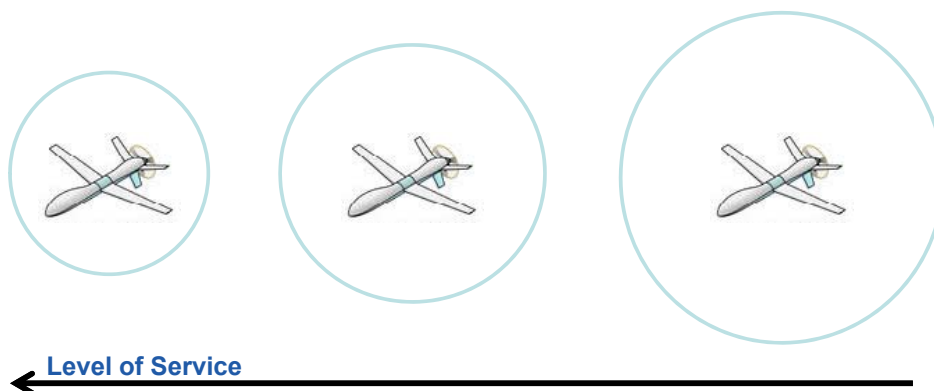

This information is the property of Embraer and cannot be used or reproduced without written consent.

SCENARIO DESCRIPTION

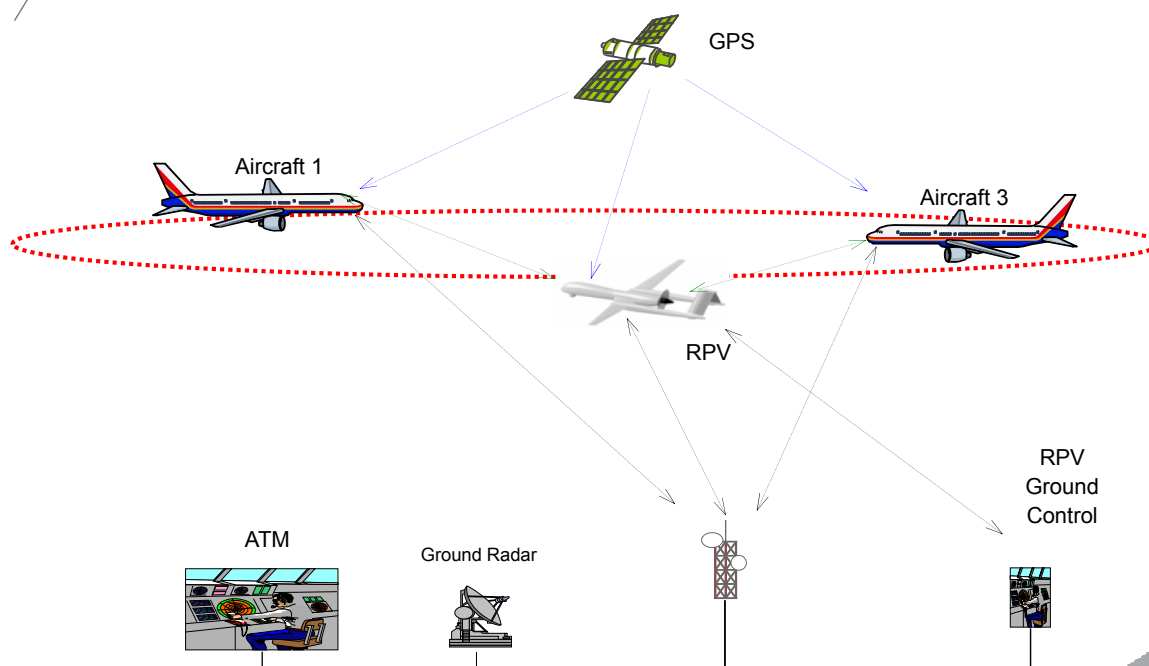

This information is the property of Embraer and cannot be used or reproduced without written consent.

SAFETY KERNEL COMPONENTS ARCHITECTURE

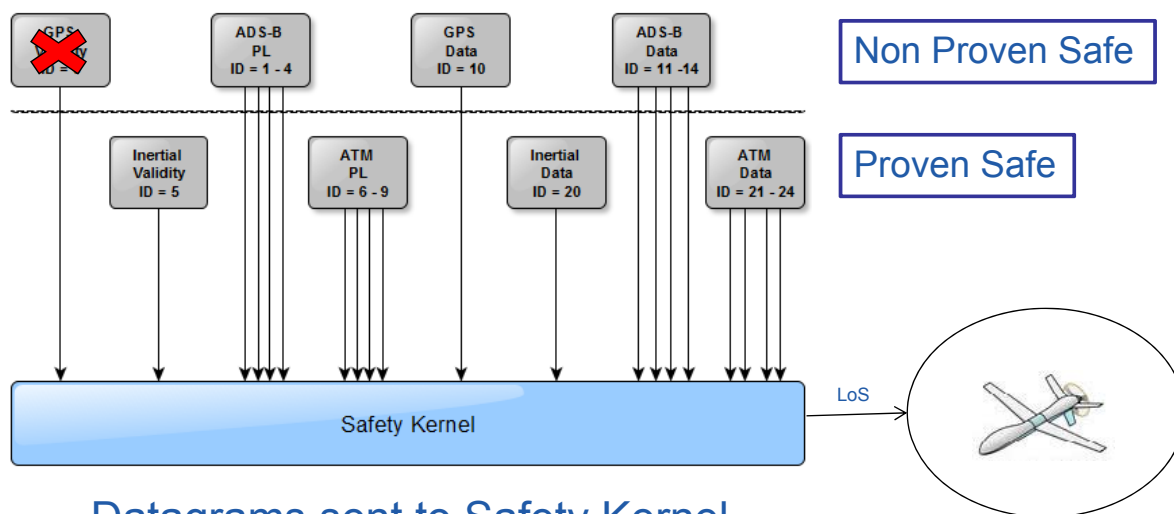

Datagrams sent to Safety Kernel

SAFETY KERNEL COMPONENTS ARCHITECTURE

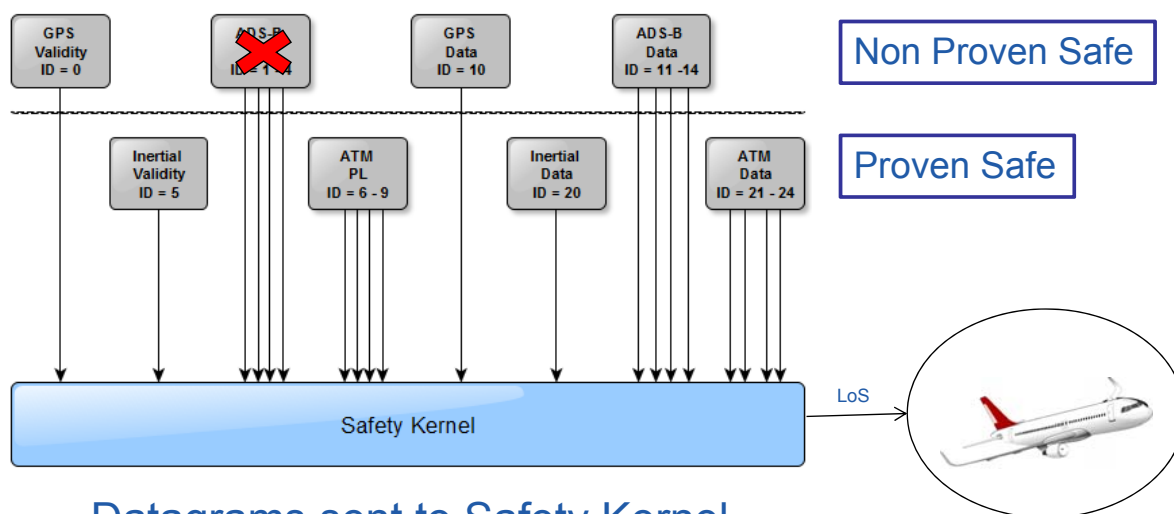

Datagrams sent to Safety Kernel

TEST ENVIRONMENT

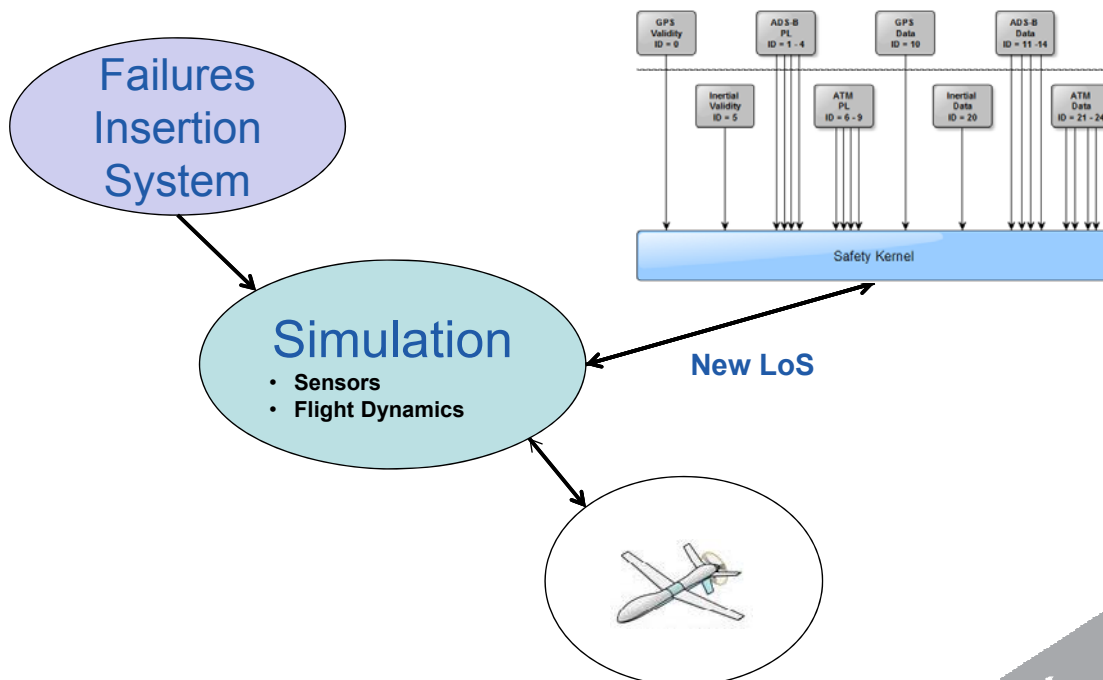

This information is the property of Embraer and cannot be used or reproduced without written consent.

DEMONSTRATIONS

1. No failure insertion. Level of Service = 2;
2. GPS PDOP = 5. Level of Service = 1.

Validity Signal	Description
1-2	Good reliability and better precision. All safety requirements are met.
2-5	Uncertainties start to have some impact on navigation. Additional measures must be taken so that flight safety is not compromised.
5-10	Poor information quality and potential threat to safety. Signals must be used carefully.
10-20	Displacement information only an estimation. Worst quality signal.

Physical interpretation of GPS validity signals

- The level of serviced calculated by the Safety Kernel becomes worse the higher the validity value.

This information is the property of Embraer and cannot be used or reproduced without written consent.